

# ProQ

BARBECUES & SMOKERS

## FLATDOG

FOLDING PORTABLE  
BBQ GRILL

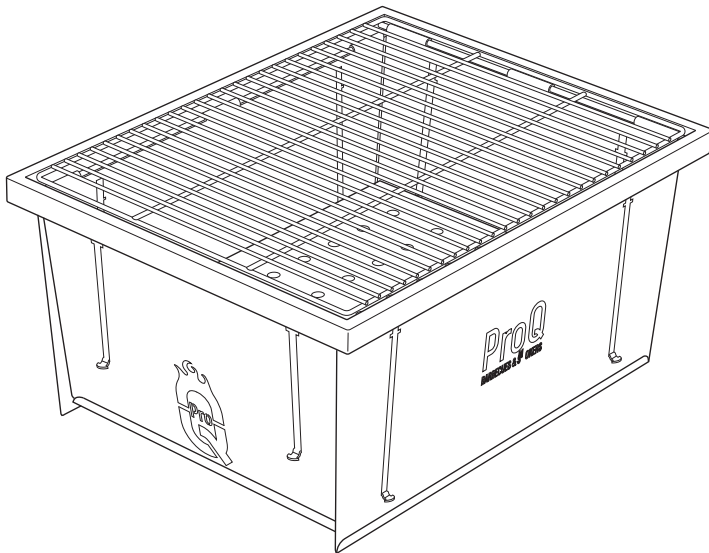

PROQSMOKERS.COM

# INTRODUCTION

Thank you for purchasing the ProQ Flatdog Portable Grill, we hope it will accompany you on many adventures! The Flatdog carries a 12 Month Warranty which covers defects due to bad workmanship or faulty materials to the original purchaser. Please keep a record of your purchase (such as order confirmation, invoice or receipt) as this will be needed to make a warranty claim. Misuse or abuse will not be covered under warranty, so please read the Safety Information & Care Instructions carefully. Some discolouration due to heat is to be expected from normal use, and will not affect the function of the grill.

# SAFETY INFORMATION

- > This unit is designed for outdoor use only. Use in a well ventilated area - do not operate indoors or in an enclosed area.
- > This grill is intended to be used with lumpwood charcoal or BBQ briquettes only, do not use wood as a fuel source.
- > Do not overfill with charcoal or use this BBQ as a firepit. This will cause warping of the steel and may impede the ability to fold flat.
- > Only use this grill on a hard, level and non-combustible surface. This grill will scorch grass or wooden tabletops. We recommend using a paving slab or a couple of bricks underneath to raise it off the ground.
- > Do not use on a plastic table or surface under any circumstances.
- > Make sure there is sufficient clearance between the unit and any combustible materials such as bushes, trees, decking and buildings.
- > Do not leave the grill unattended when lit and keep children and pets away at all times.
- > Use suitable BBQ/oven mitts when handling your BBQ, as the surfaces will become hot, especially when adding more fuel to the fire. Do not move the grill when lit.
- > Ensure the fire is completely extinguished and allow the grill to cool down before emptying the ash and re-folding. Be careful of embers, and use BBQ/oven mitts when emptying ash.



## CARE INSTRUCTIONS

- > Avoid pouring water into a hot BBQ, this will damage the body and may cause warping or cracking which will stop the grill from being able to fold easily.
- > Wash with warm, soapy water and allow to dry thoroughly after every use and before storing – this will avoid any corrosion. The cooking grill is dishwasher safe.
- > The use of abrasive cleaners or sharp objects can damage the surfaces. We recommend using wooden or plastic (once cold) cleaning utensils. If required, you can disassemble the unit and clean each piece separately.

## SETUP

1. Hold the BBQ flat as shown and keeping a grip on the frame, allow the bottom to drop down slowly.

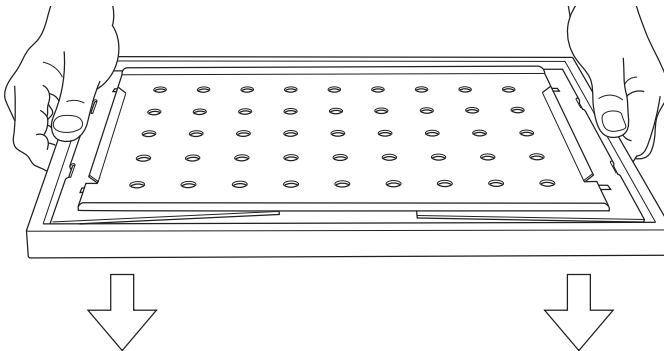

2. Ensure the charcoal tray is all the way down with a gentle shake - that's it! You're ready to start your fire.

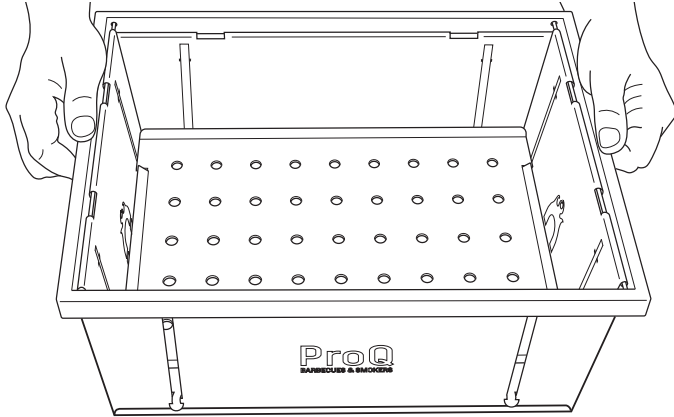

*Remember: Don't overfill the grill with charcoal, a couple of inches in the bottom is all you need.*

## CLEANUP

1. Lift up one side of the charcoal tray using the slide tabs.

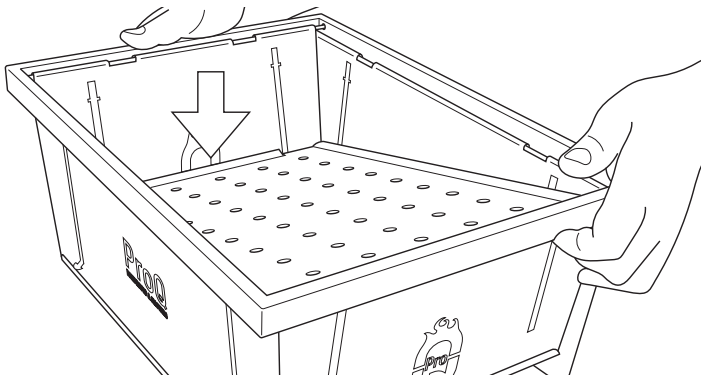

## CLEANUP

2. Push in the side of the BBQ so that it sits under the charcoal tray.

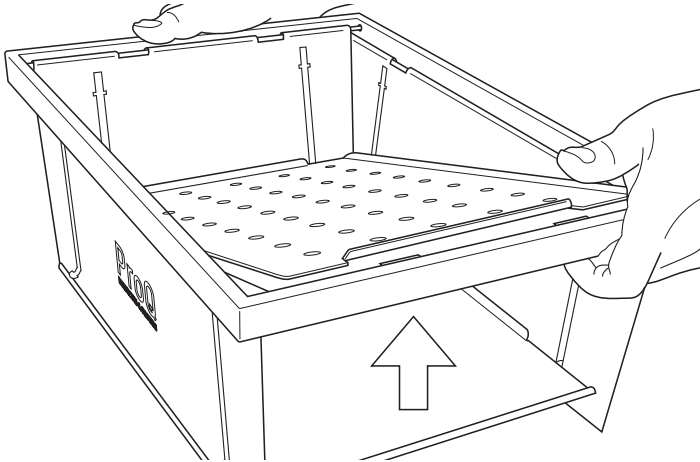

3. Tip the ash out into a suitable non-flammable container.

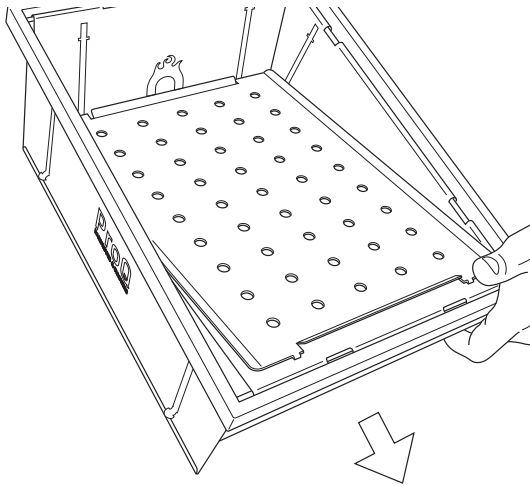

*Remember: Ensure the fire is completely extinguished and allow the grill to cool down before emptying the ash and re-folding. Be careful of embers, and use BBQ/oven mitts when emptying ash.*

*Wash with warm, soapy water and allow to dry thoroughly after every use and before storing – this will avoid any corrosion – the cooking grill is dishwasher safe.*



## PACKING AWAY

1. Remove the cooking grill & grab the frame of the BBQ.

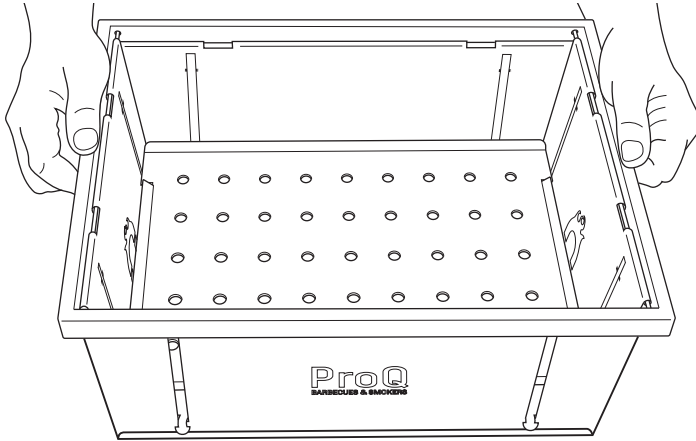

2. Flip the whole BBQ over in a smooth motion.

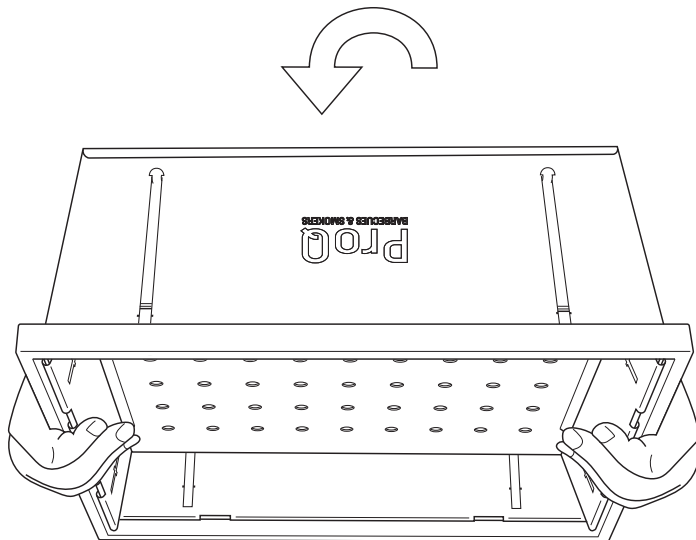

## PACKING AWAY

3. Allow the grill to fold in on itself, give it a wiggle if it needs help.

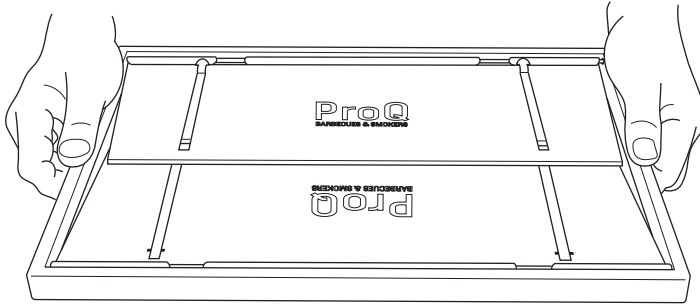

4. Pop the grill into the gap and pack it away until next time.

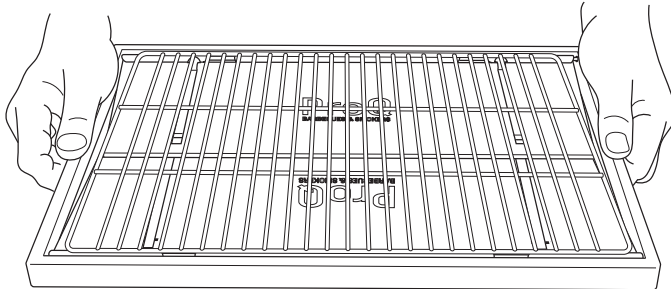

*Tip: If you're planning to store your grill for a while, lightly coat it in cooking oil to protect against corrosion.*





INFO@PROQSMOKERS.COM

ProQ is a Registered Trademark of Mac's BBQ Ltd.

PROQSMOKERS.COM